



Lavochkin

La-5

The La-5 Fighter was born, when the inline-engine driven LaGG-3 proved less successful than had been anticipated, and was modified to be powered by the Shvetsov ASh-82 radial engine. The new engine finally brought out the performance, that had been planned for the LaGG-3, but as Lavochkin worked alone on it, the new plane was simply called La-5. The original La-5 was brought into front service swiftly, where it showed great promise, even though it was still riddled with the typical bugs of the LaGG-3, such as constant oil leaks, bad ventilation in the Cockpit and a canopy,

that wouldn't open in cases of emergency. Still, it proved to be the first soviet fighter to match the performance of the

German Me 109 and Fw 190. It was inferior to those two types at high altitude, but a good match at the low altitudes flown over the eastern front. It also rolled very fast.

The La-5 was further developed, when an improved version of the ASh-82 engine, the ASh-82F, became available. The rear section of the fuselage was cut down to create a better view from the cockpit. Another improvement was the La-5FN which received a supercharged

version of the ASh-82 engine. This required the addition of a air intake for the supercharger on the top of the cowling, which became the characteristic feature of the La-5FN. The La-5FN was the definitive version of the La-5, with its high performance, fast turn radius and heavy armament.

The La-5 was, like the LaGG-3, mostly build of wood, which made it heavier than metal-build aircraft, but allowed it to take a lot of damage. It also gave the rear fuselage a smooth, almost seamless surface. 9920 La-5's of all versions, including the Trainer version La-5UTI,

were build. After the end of World War II, most La-5's were put out of service, as their wooden structure made them more difficult to preserve than their improved predecessor, the La-7. A few La-5's were flown by the Czechoslovakian Air Force in their own Markings after the war.

The most famous single La-5 was probably the La-5Fn "white 14", which was flown by three leading soviet Aces: Snr. Lt. Pavel Bryzgalov, Capt. Kyrill Evstigneev and Capt. Ivan Kozhedub. Kozhedub went on to become the leading allied ace of World War 2 after converting to the La-7.

1. Build the wing stiffener

If you want to build the La-5 with landing gear down, jump to 4

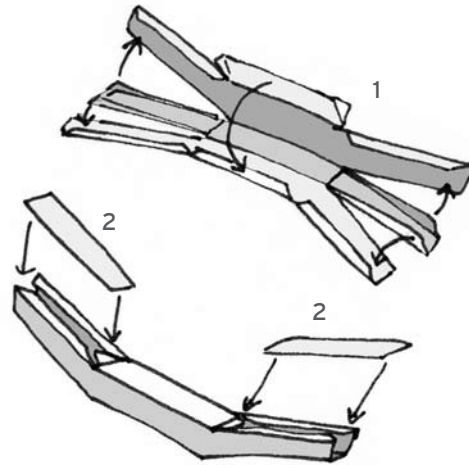

! Part 4 and the wheel well look slightly different on the Luftwaffe 2 version, but are build the same way

2. Cut out the marked holes on the wing.

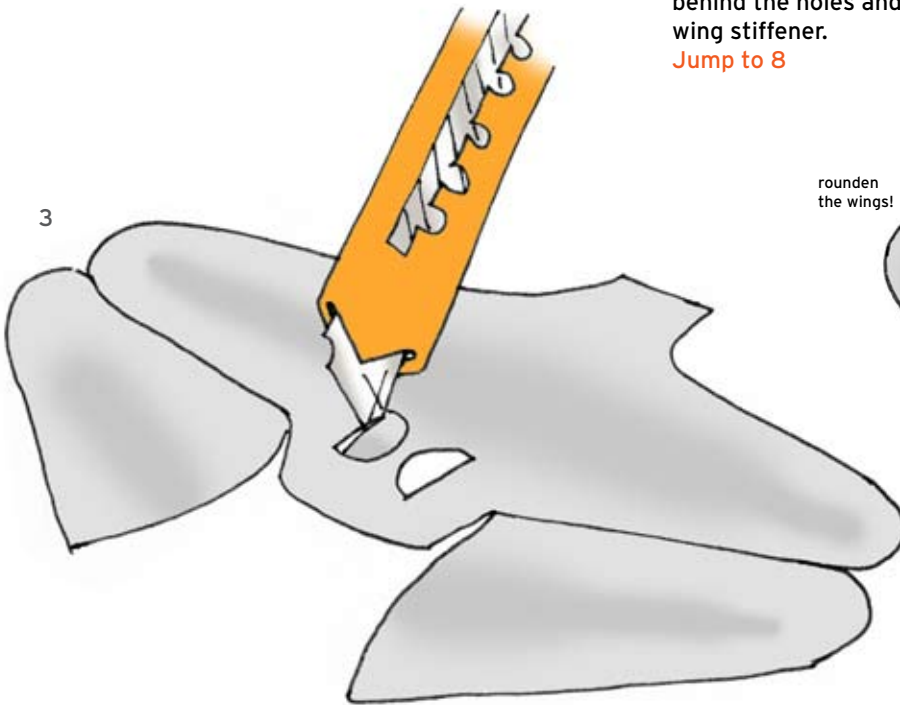

3. Glue the wheel openings behind the holes and attach the wing stiffener. Jump to 8

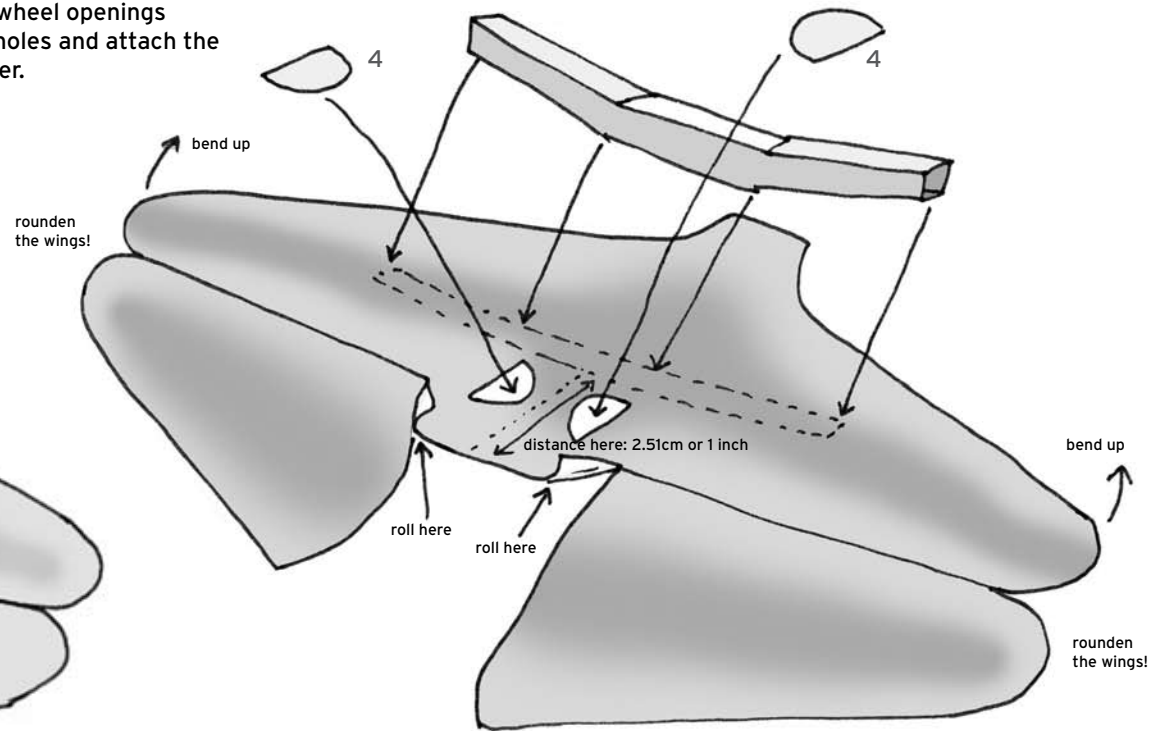

4. Cut out the wheel wells. You don't need to keep the cut out part.

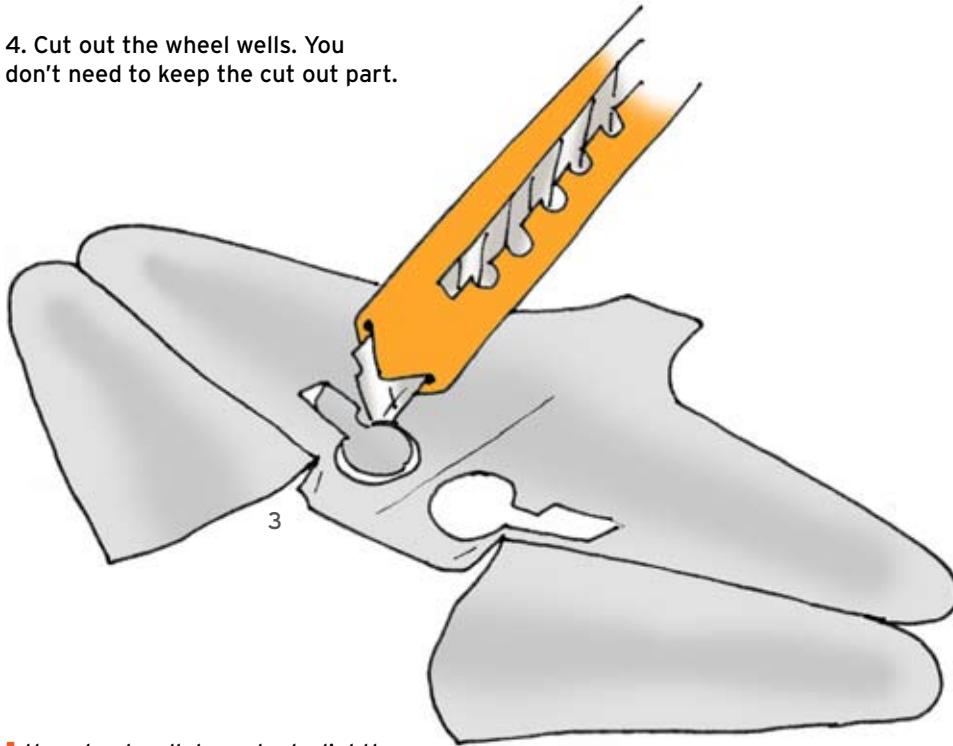

! the wheel well doors look slightly different on the **Luftwaffe 2 version**, but are build the same way

5. Fold and glue together the wheel well walls.

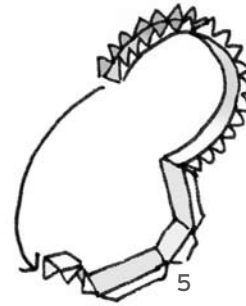

6. Glue the wheel well walls on the wheel well roof. Make sure that the bend up part is glued on it.

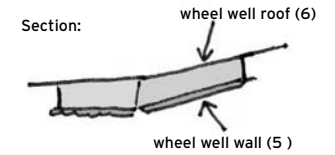
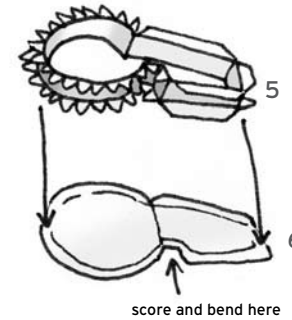

7. Install the wheel wells and the wing stiffener.

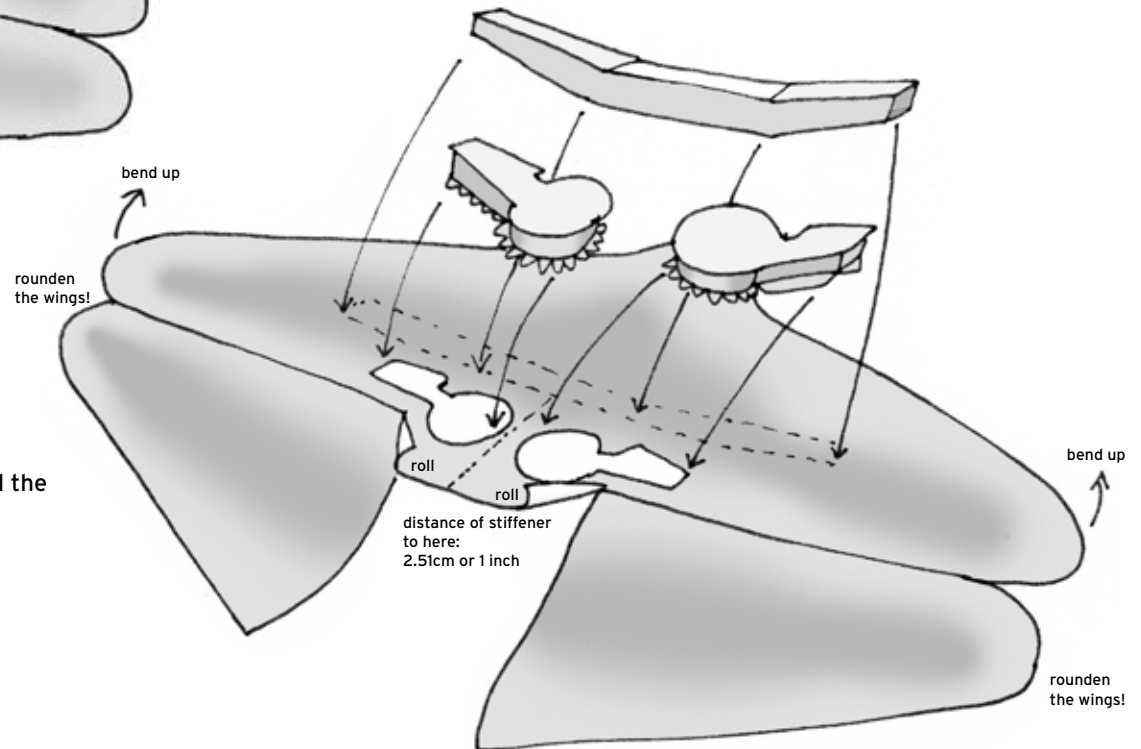

8. Fold the upper wing surfaces and glue on the lower surfaces. Make sure to create an Airfoil

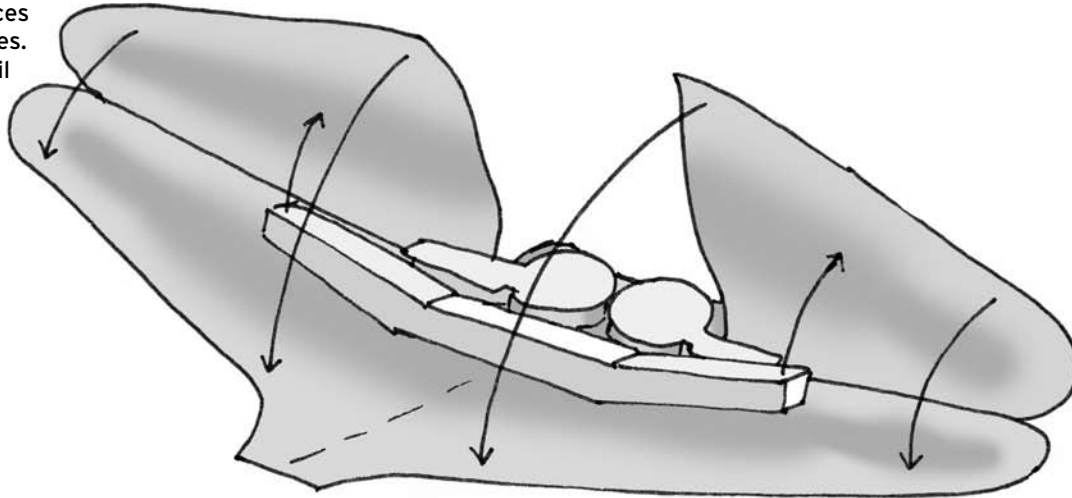

9. Glue the upper middle part of the wing in the center. Make sure to rounden the leading edge wing root good enough.

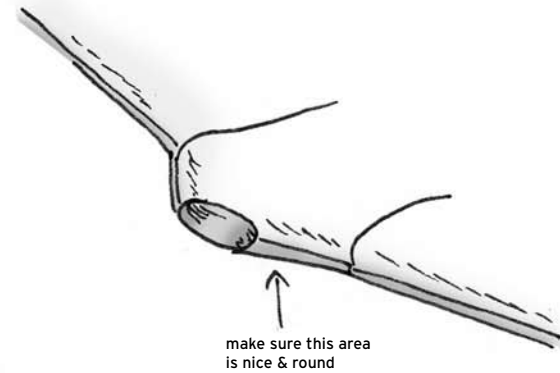
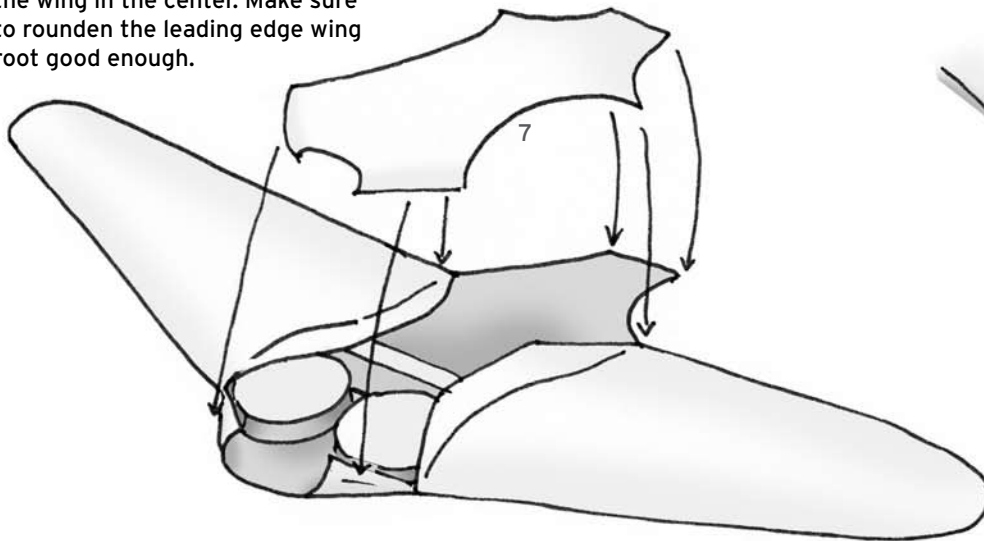

10. Roll the main fuselage.
Then glue it together, from the tail
to the front.

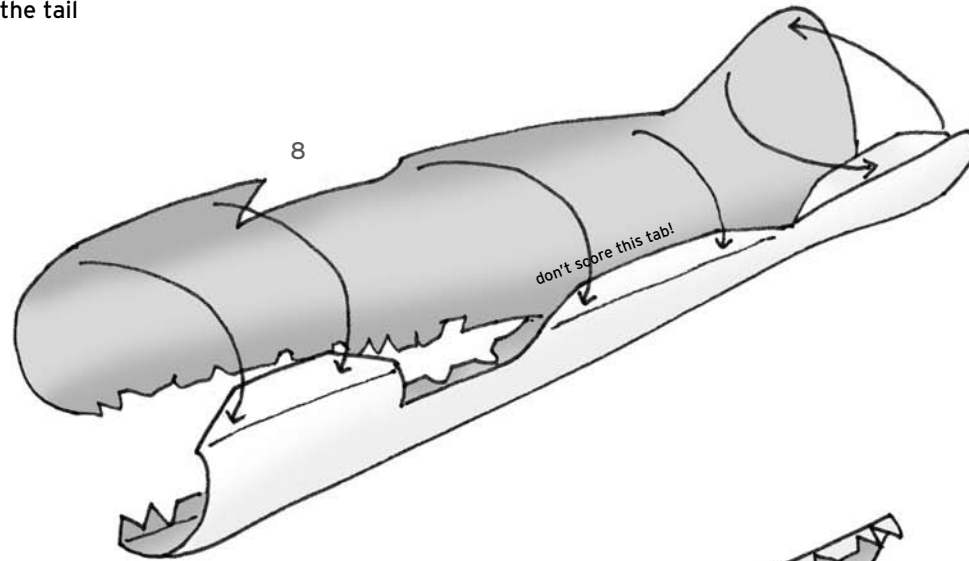

11. Glue the little overlap in the bottom.
Form the fuselage to the sections shown

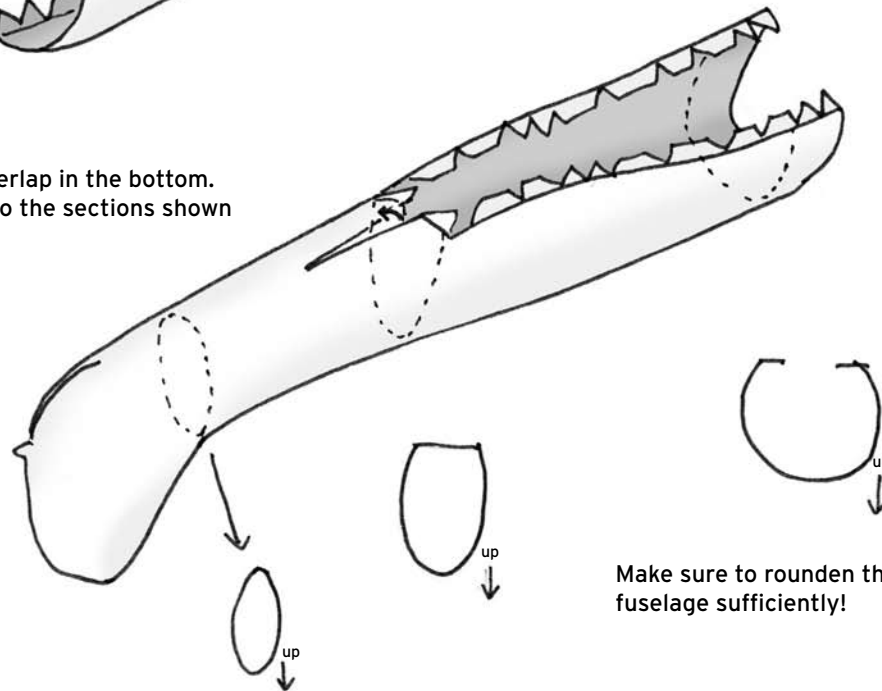

Make sure to rounden the rear
fuselage sufficiently!

12. Cut out the engine plate and cut in as shown

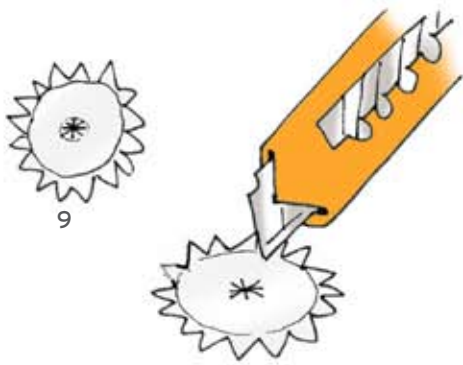

13. Roll the cowling around the engine plate and glue the propeller shaft through the engine plate. align as seen in the section

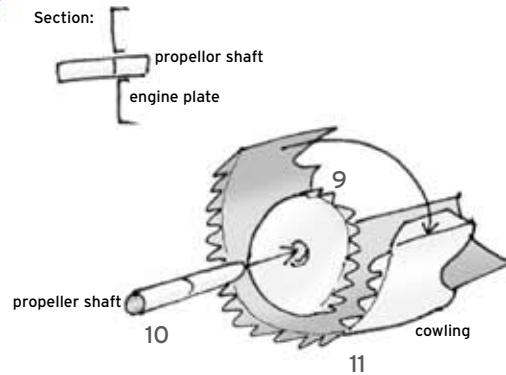

14. Complete the cowling by adding the front sections. On the La-5FN and Czechoslovak La-5UTI versions, cut in the exhaust flap and bend it slightly outward.

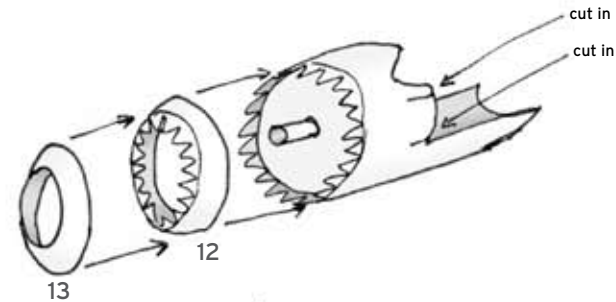

Roll & glue this part first, then cut away the white part.

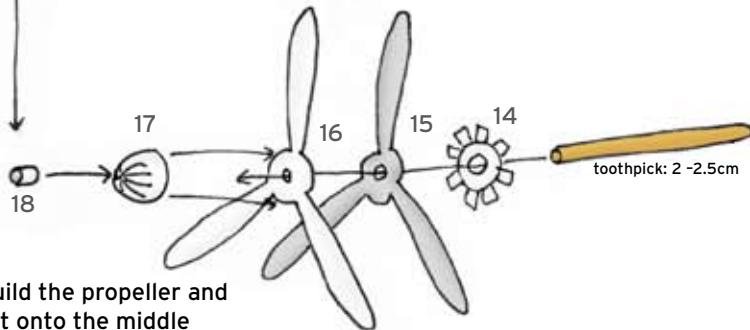

15. Build the propeller and glue it onto the middle part of a toothpick

17. Push the Propeller through the shaft. Don't glue !

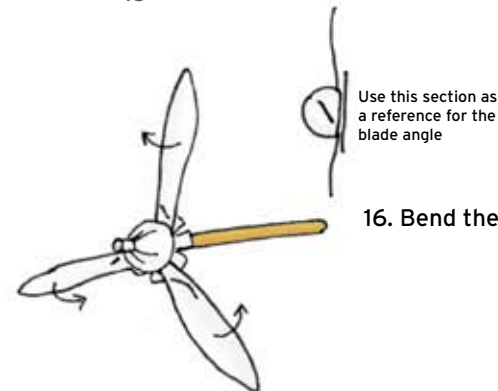
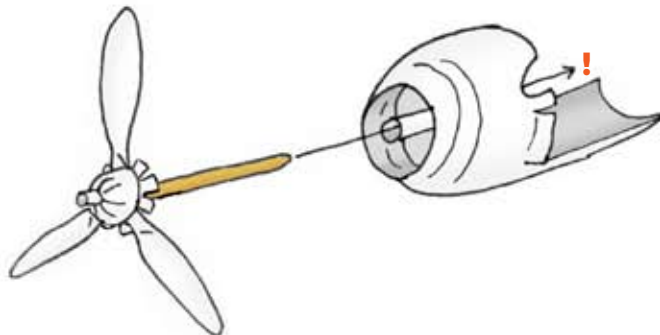

16. Bend the propeller blades

18. Glue the shaft hub to the end. Make sure no glue gets between toothpick and shaft.

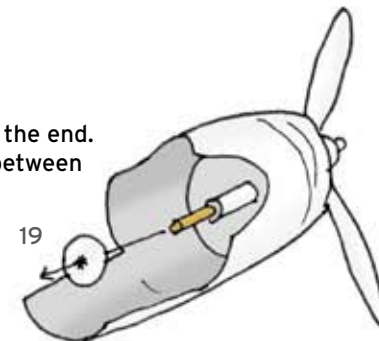

19. Main Assembly: Glue the fuselage to the marked position on the wing first. Then push and glue the Engine on both from the front.

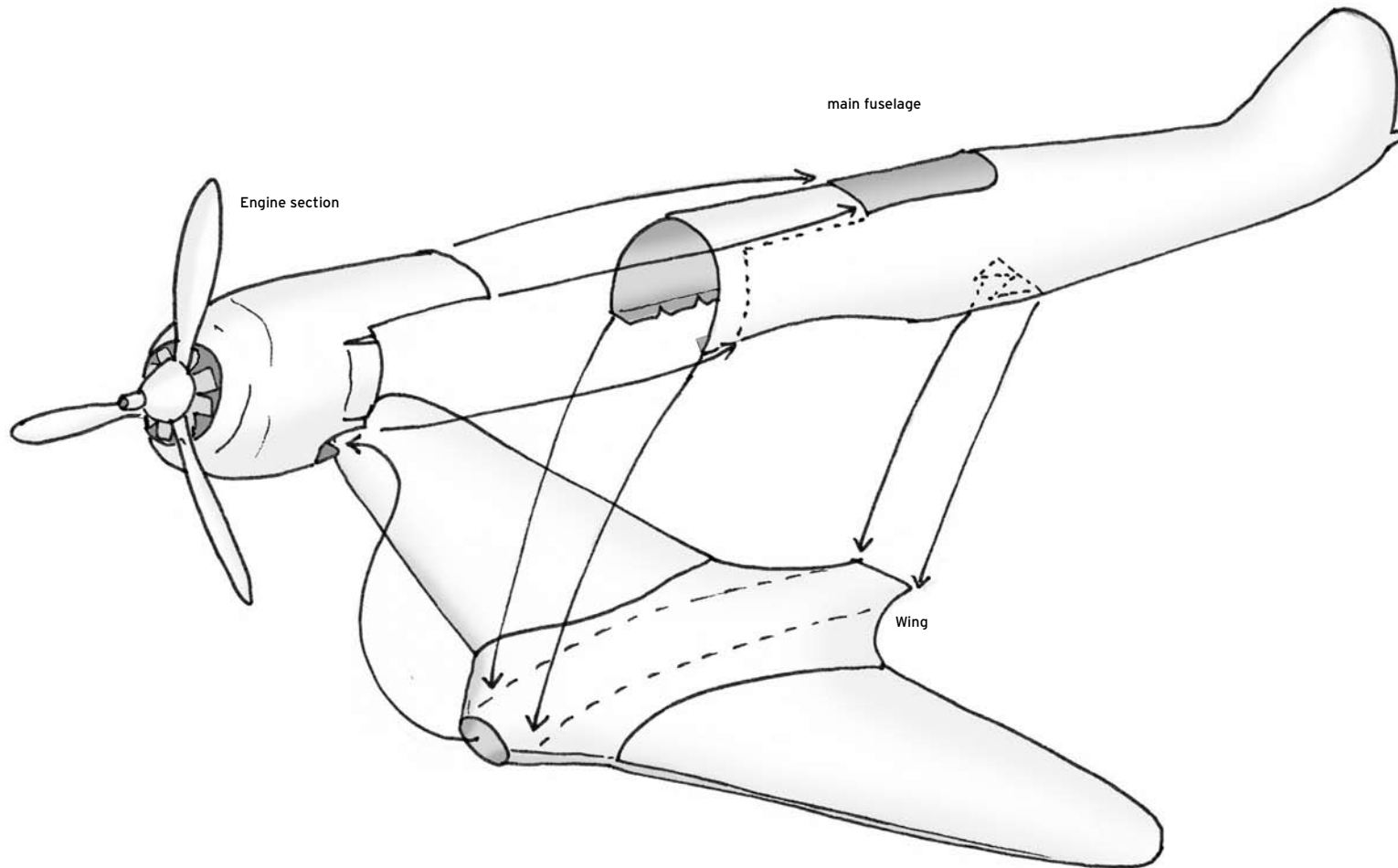

20. Attach details: Sufficiently rounden the wing roots and canopies. Make Airfoils on the horizontal stabilizers

For the canopies of La-5 and La-5UTI see next page

Supercharger Intake (La-5FN & Czechoslovak La-5UTI)

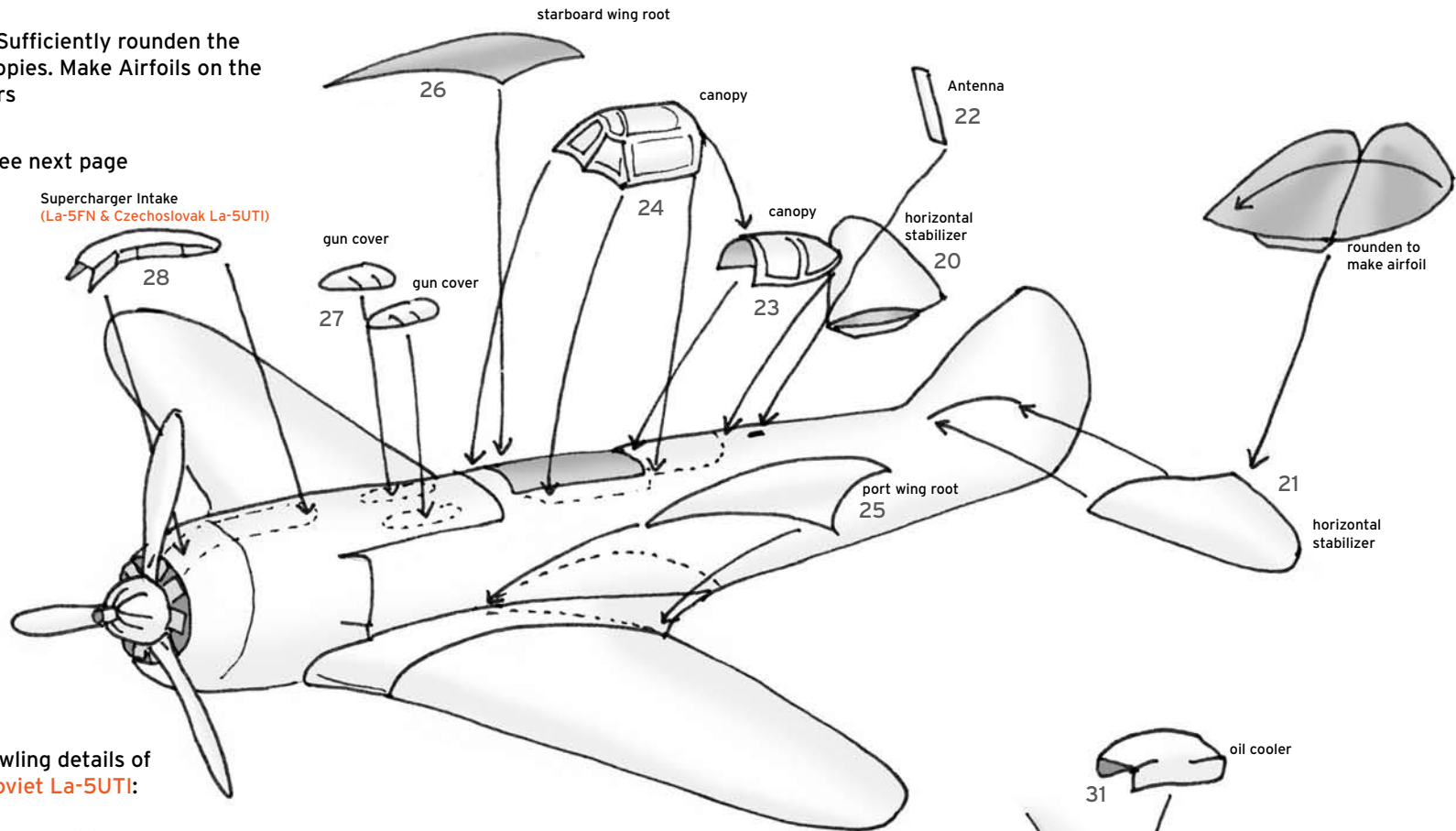

See this for the cowling details of La-5, La-5F and Soviet La-5UTI:

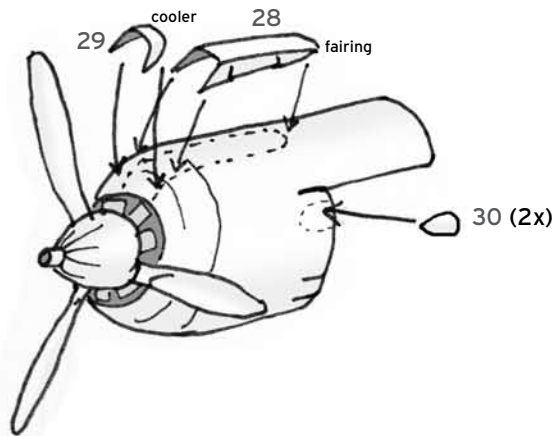

21. Attach the Oil cooler under the cowling, across the edge between wing and cowling

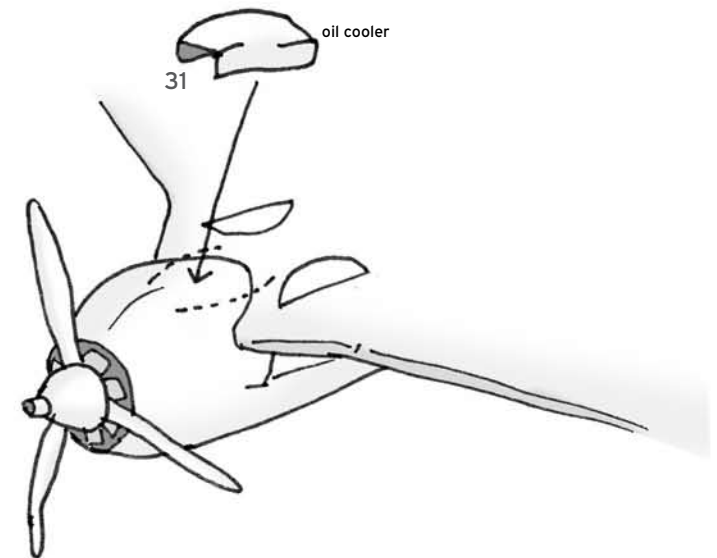

Installation of Canopy and Antenna on the La-5

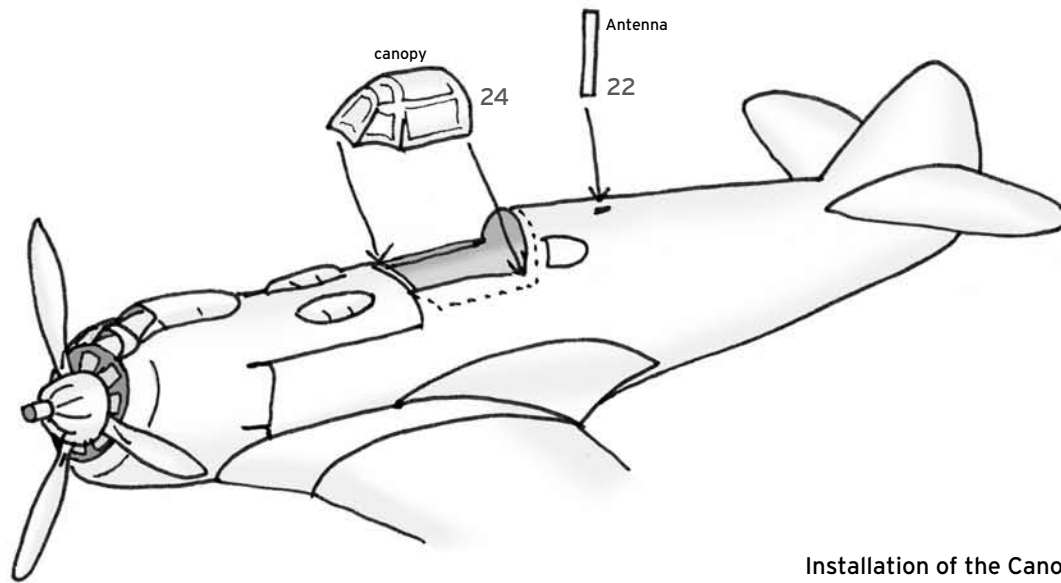

Installation of the Canopy on the La-5

(no antenna)

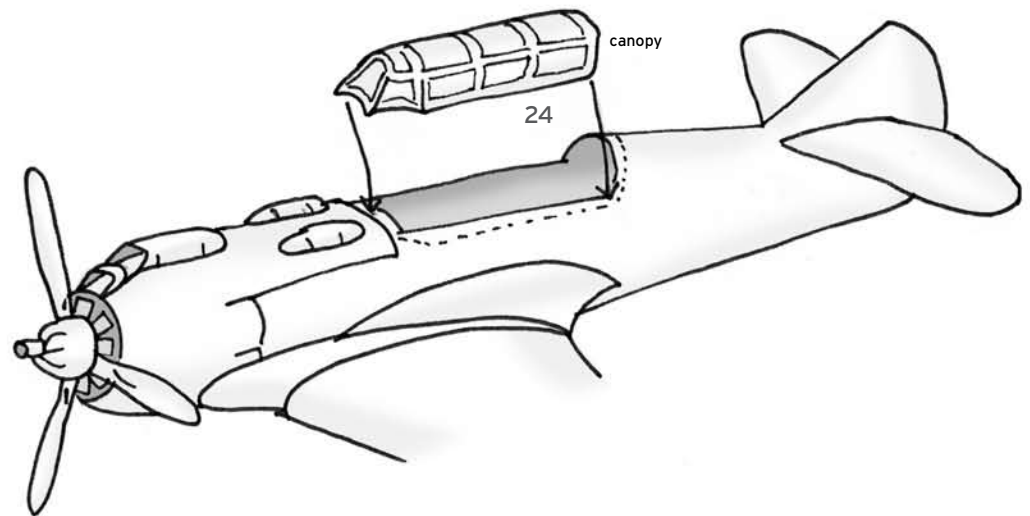

It you don't build the Landing Gear down, your model is finished!

22. Landing Gear Installation

